

Incremental encoder with shaft



Features

- Low cost incremental encoder for industrial use
- Number of pulses up to 1024 pulses/rev.
- Centering seat $\text{Ø}50$ mm, mounting punch circle $\text{Ø}68$ mm
- TTL- or HTL- output signals
- Cable outlet radial or axial
- Connector version optional



drawing-no.: 027- 4

Mechanical data

Design	B14	B14
Housing	aluminium, black, powder coated	
Protection	IP 65	according to DIN EN 60 529 IP65
Construction principle	OPSiC with slotdisc	
max. revolution (mechanical)	$n_{\max} \leq 12\,000 \text{ min}^{-1}$	(observe limit frequency)
Permissible shaft load	axial $\leq 20 \text{ N}$ radial $\leq 40 \text{ N}$	(at shaft end)
Starting torque	at 20 °C $\leq 1 \text{ Ncm}$	
Vibration	55... 2000 Hz $\leq 100 \text{ m/s}^2$	according to DIN IEC 60 068, part 2 - 6
Shock	11 ms $\leq 1000 \text{ m/s}^2$	according to DIN IEC 60 068, part 2 - 27
Shaft diameter	d 6 mm	6
Weight	approx. 310 g	

Electrical data

Number of pulses	Z	50, 60, 64, 88, 90, 100, 120, 128, 200, 250, 254, 256, 360, 400, 500, 512, 600, 1000, 1024 pulses/rev.	XXXX
Electronic version (output signals)	TTL	Line driver-output stage, supply voltage: $U_B = 5 \text{ VDC} \pm 5\%$ (polarity protected), output amplitude: $U_{\text{LOW}} \leq 0.5 \text{ V}$, $U_{\text{HIGH}} \geq 2.5 \text{ V}$	T
	HTL	Push pull-output stage (short-circuit proof), supply voltage: $U_B = 8 - 30 \text{ VDC}$ (polarity protected), output amplitude: $U_{\text{LOW}} \leq 1.5 \text{ V}$, $U_{\text{HIGH}} \geq U_B - 3 \text{ V}$	H
Output signals	A, B + Inv.	2 square wave pulse trains, electr. phase shifted 90° + signal inverting	BI
Limit frequency	f_G	120 kHz	
Output load current	I_{Load}	$\leq 70 \text{ mA}$	
Current consumption (no-load)	I_{max}	$\leq 100 \text{ mA}$	
Permissible cable length		$\leq 100 \text{ m}$ (Baumer Thalheim cable)	
Type of connection		cable, radial, 1.0 m (standard length)	KR1
Operating temperature range		-20°C to $+70^\circ \text{C}$	S
Permissible relative humidity		$\leq 90\%$ (condensation not permitted)	

Options

Electronic version		TTL-output signals, Line driver-output stage, supply voltage: $U_B = 8 - 30 \text{ VDC}$ (polarity protected)	R
Output signals	A, B, N + Inv.	2 square wave pulse trains + zero pulse, electr. length 90° + signal inverting	NI
Type of connection	cable connector	cable, axial, ... m performed at cable, (ref. data sheet »Type of performed cables«)	KA... ...
Operating temperature range		-20°C to $+100^\circ \text{C}$	E

Accessories

Eccentric disc-set type A (3 pcs.)	article-no.: 40701-3
------------------------------------	----------------------

Connection table

wire color	signals
brown	A
green	A inv.
grey	B
pink	B inv.
red	N
black	N inv.
brown 0.5 mm ²	+ U_B
white 0.5 mm ²	0 V
blue	+ U_{sensor}
white	0 V_{sensor}
transparent	shielding/housing

Output signal diagram

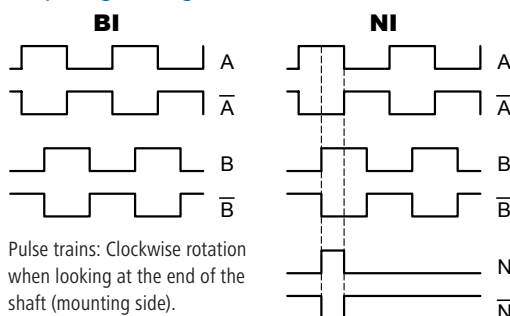

Ordering example:

ITD 20	B14	500	H	BI	KR1	S	6	IP65	
Incremental encoder ITD 20	Design B14	Number of pulses 500 pulses/revolution	Electronic version $U_B = 8 - 30 \text{ VDC HTL}$	Output signals A, B-track + inv.	Type of connection cable, radial 1 m	Operating temperature range -20°C to $+70^\circ \text{C}$	Shaft diameter 6 mm	Protection IP65	Attachment kit variant

Baumer Thalheim GmbH & Co. KG

Hessenring 17, D-37269 Eschwege, Germany

Phone: +49 (0)5651 9239-0 · Fax: +49 (0)5651 9239-80 · www.baumerthalheim.com